

Agilent 8719D, 8720D, and 8722D Network Analyzers

Data Sheet

8719D 50 MHz to 13.5 GHz
8720D 50 MHz to 20 GHz
8722D 50 MHz to 40 GHz

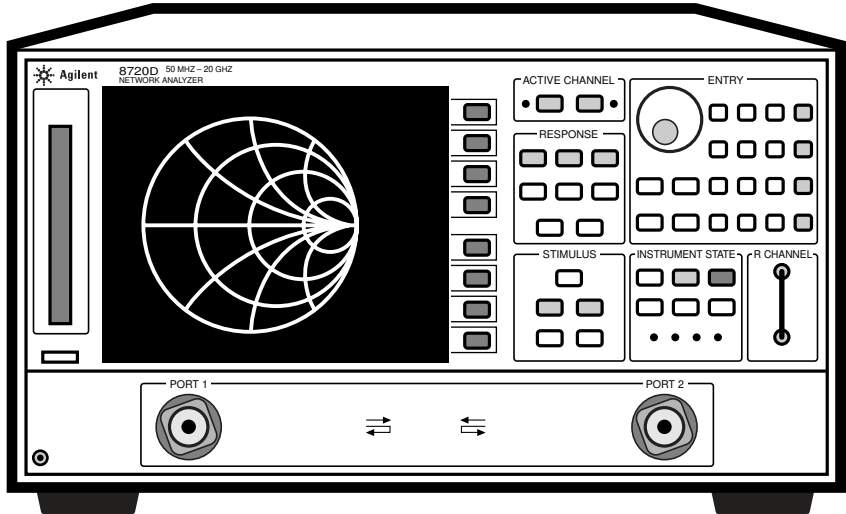

Table of Contents

2	Definitions and test conditions
3	System performance
	Instruments with multiple options
3, 4, 5	Standard (no options) Standard Instrument Performance Option 400 (four samplers for TRL) Also includes these configurations combined with Options 089 and/or 012
6, 7, 8	Option 007 (mechanical switch) Option 007/085 Performance Option 085 (high power) Also includes these configurations combined with Options 089 and/or 012
9	Option 012
10	Option 089
11	Specifications and characteristics
12	Measurement throughput summary
13	Analyzer options
15	Capabilities
22	Software
24	Accessories



Agilent Technologies

Innovating the HP Way

Definitions and Test Conditions

This data sheet provides two types of performance information:

- System Specifications
- Supplemental Characteristics

System specifications describe the instrument's warranted performance over the temperature range of $23\text{ }^{\circ}\text{C} \pm 3\text{ }^{\circ}\text{C}$ (except where noted).

Supplemental characteristics describe the instrument's non-warranted performance parameters.

System dynamic range

These specifications apply to transmission measurements in the full frequency range at 10 Hz IF BW with response and isolation correction or full two-port calibration. Dynamic range is limited by maximum receiver input level and the receiver's noise floor.

Measurement uncertainty

Curves show the worst-case magnitude and phase uncertainty for reflection and transmission measurements, after calibration. Calibration is the process of measuring known standards from a calibration kit to characterize a network analyzer's systematic (repeatable) errors.

Reflection measurement uncertainty is plotted as a function of S_{11} (reflection coefficient). Based on a one-port calibration, using specified calibration kit, with 10 Hz IF bandwidth and no averaging. Assumes a one-port device ($S_{21}=S_{12}=0$).

Transmission measurement uncertainty is plotted as a function of S_{21} (transmission gain/loss, in dB from reference level). Assumes a well-matched device ($S_{11}=S_{22}=0$). Based on a full two-port Short-Open-Load-Thru calibration (including isolation with averaging factor of 8), using specified calibration kit, with 10 Hz IF bandwidth and no averaging.

Measurement port characteristics

The characteristics indicate performance after error-correction (full two-port calibration). The performance accuracy is determined by the quality of calibration standards and how well "known" they are, plus system repeatability, stability, and noise. Crosstalk is not shown, since isolation calibration will reduce crosstalk to the noise floor.

System performance

Agilent 8719D, 8720D with 3.5 mm test ports

Standard, Options 400, 012, 089, or any combination of these options

Calibration kit: Agilent 85052B, 3.5 mm with sliding loads

Cables: Agilent 85131F 3.5 mm flexible cable set

IF bandwidth: 10 Hz

Averaging: None (8 during isolation calibration)

System dynamic range

0.05 to 2 GHz	100 dB ¹
2 to 8 GHz	100 dB
8 to 20 GHz	100 dB

1. Rolls off below 840 MHz to 77 dB at 50 MHz

Corrected measurement port characteristics

	Frequency Range (GHz)			
	0.05 to 0.5	0.5 to 2	2 to 8	8 to 20
Directivity	48 dB	48 dB	44 dB	44 dB
Source Match	40 dB	40 dB	33 dB	31 dB
Load Match	48 dB	48 dB	44 dB	44 dB
Reflection Tracking	±0.006 dB	±0.006 dB	±0.006 dB	±0.008 dB
Transmission Tracking	±0.017 dB	±0.018 dB	±0.066 dB	±0.099 dB

Maximum output power

+5 dBm

Measurement uncertainty

Reflection measurements

8720D with 85052B Calibration Kit

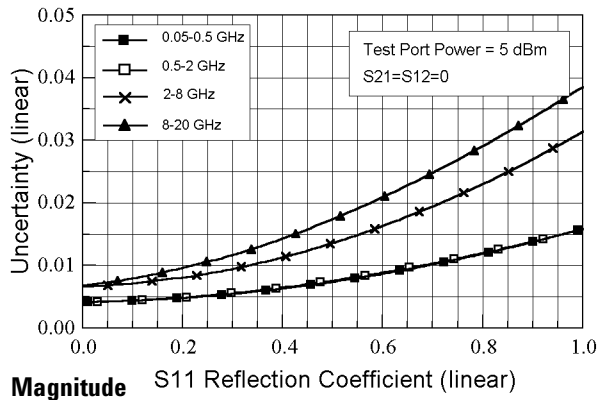

8720D with 85052B Calibration Kit

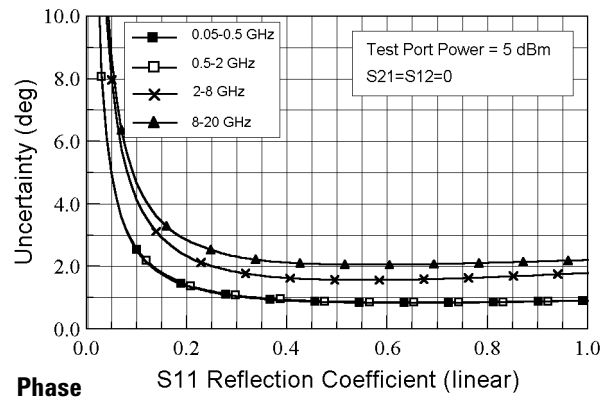

Transmission measurements

8720D with 85052B Calibration Kit

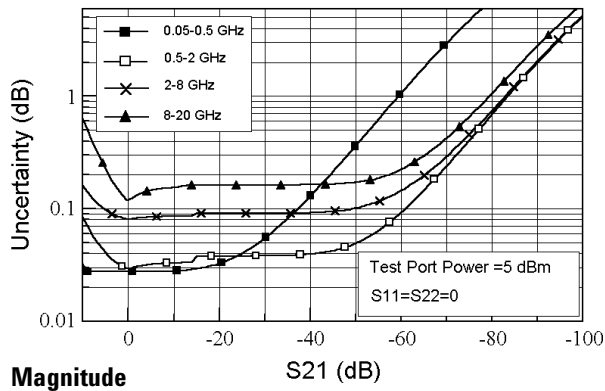

8720D with 85052B Calibration Kit

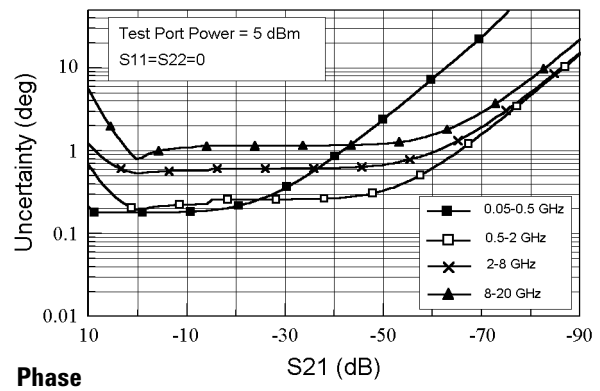

System performance (continued)

Agilent 8722D with 2.4 mm test ports

Standard, Options 400, 012, 089, or any combination of these options.

Calibration kit: Agilent 85056A, 2.4 mm with sliding loads

Cables: Agilent 85133F 2.4 mm flexible cable set

IF bandwidth: 10 Hz

Averaging: None (8 during isolation calibration)

System dynamic range

0.05 to 2 GHz	93 dB ¹
2 to 8 GHz	93 dB
8 to 20 GHz	91 dB
20 to 40 GHz	80 dB

1. Rolls off below 840 MHz to 72 dB at 50 MHz

Corrected measurement port characteristics

	Frequency Range (GHz)			
	0.05 to 2	2 to 8	8 to 20	20 to 40
Directivity	42 dB	42 dB	42 dB	38 dB
Source Match	41 dB	38 dB	38 dB	33 dB
Load Match	42 dB	42 dB	42 dB	38 dB
Reflection Tracking	±0.005 dB	±0.010 dB	±0.010 dB	±0.021 dB
Transmission Tracking	±0.020 dB	±0.038 dB	±0.048 dB	±0.110 dB

Maximum output power

0.05 to 20 GHz: -5 dBm

20 to 40 GHz: -10 dBm

Measurement uncertainty

Reflection measurements

8722D with 85056A Calibration Kit

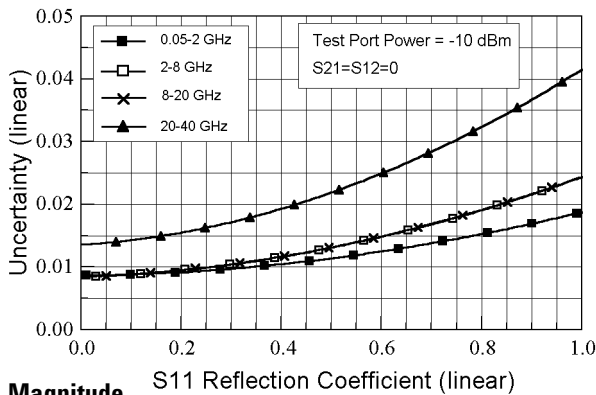

Magnitude

8722D with 85056A Calibration Kit

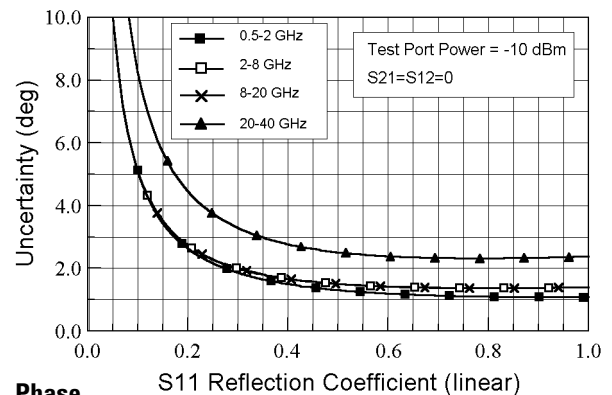

Phase

Transmission measurements

8722D with 85056A Calibration Kit

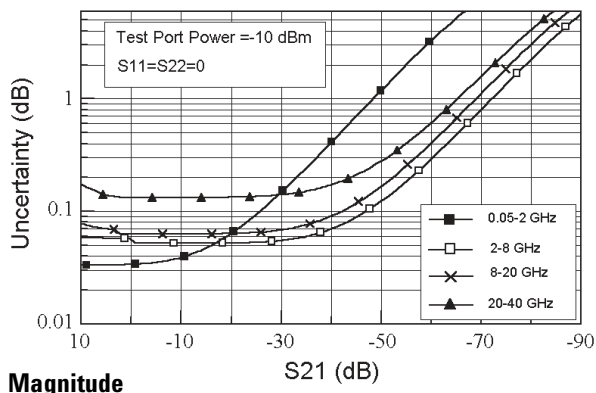

Magnitude

8722D with 85056A Calibration Kit

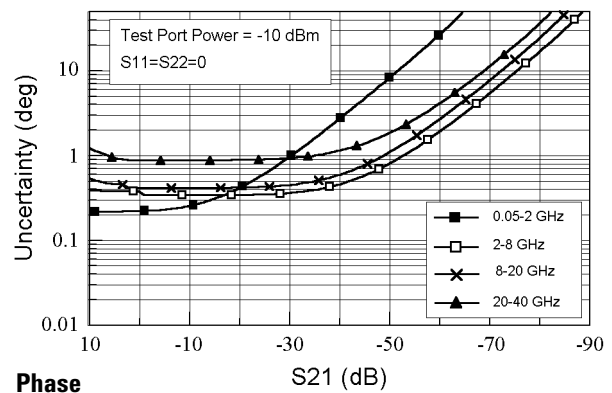

Phase

Agilent 8719D Option 400
Agilent 8720D Option 400
Agilent 8722D Option 400
(with 3.5 mm test ports using TRL)
Includes instruments with Options 012 and/or 089

Calibration kit: Agilent 85052C, 3.5 mm for TRL
Cables: Agilent 85131F 3.5 mm flexible cable set
IF bandwidth: 10 Hz
Averaging: None (8 during isolation calibration)

System dynamic range

Frequency Range	8719D/8720D	8722D
0.05 to 2 GHz	100 dB ¹	93 dB ²
2 to 8 GHz	100 dB	93 dB
8 to 20 GHz	100 dB	91 dB
20 to 40 GHz	—	80 dB

1. Rolls off below 840 MHz to 77 dB at 50 MHz
 2. Rolls off below 840 MHz to 67 dB at 50 MHz

Measurement uncertainty

Reflection measurements

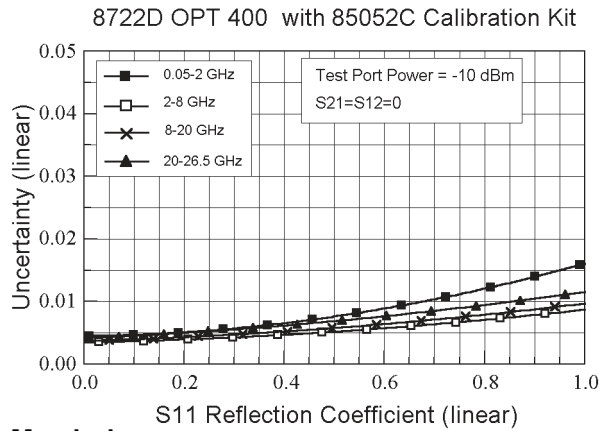

Magnitude

Transmission measurements

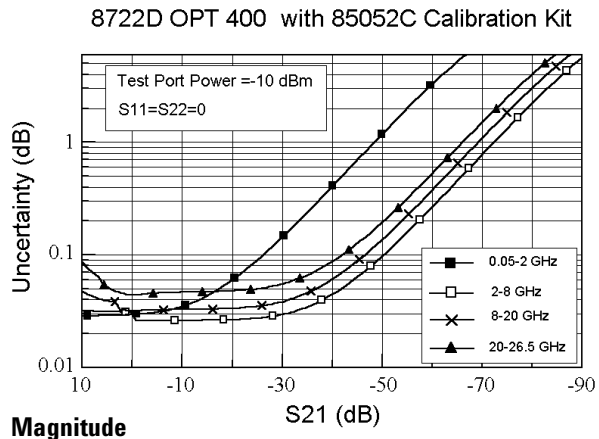

Magnitude

Corrected measurement port characteristics

8719D/8720D Option 400

	Frequency Range (GHz)			
	0.05 to 0.5	0.5 to 2	2 to 8	8 to 20
Directivity	48 dB	48 dB	50 dB	50 dB
Source Match	40 dB	40 dB	50 dB	50 dB
Load Match	48 dB	48 dB	50 dB	50 dB
Reflection Tracking	±0.006 dB	±0.006 dB	±0.005 dB	±0.005 dB
Transmission Tracking	±0.020 dB	±0.026 dB	±0.015 dB	±0.019 dB

8722D Option 400

	Frequency Range (GHz)			
	0.05 to 2	2 to 8	8 to 20	20 to 26.5
Directivity	48 dB	50 dB	50 dB	50 dB
Source Match	40 dB	50 dB	50 dB	50 dB
Load Match	48 dB	50 dB	50 dB	50 dB
Reflection Tracking	±0.006 dB	±0.005 dB	±0.005 dB	±0.005 dB
Transmission Tracking	±0.017 dB	±0.013 dB	±0.016 dB	±0.023 dB

Maximum output power

8719D/8720D: +5 dBm

8722D (0.05 to 20 GHz): -5 dBm

(20 to 40 GHz): -10 dBm

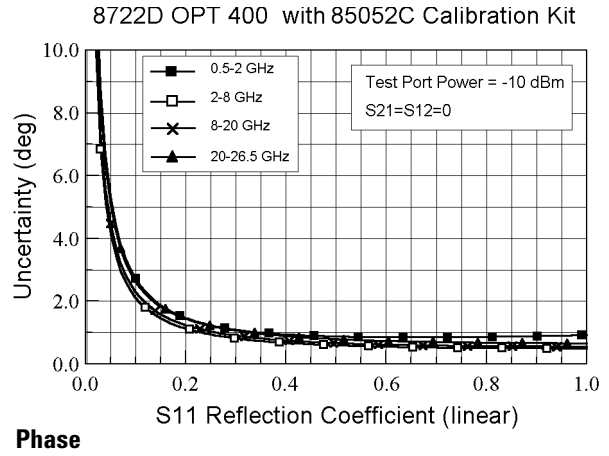

Phase

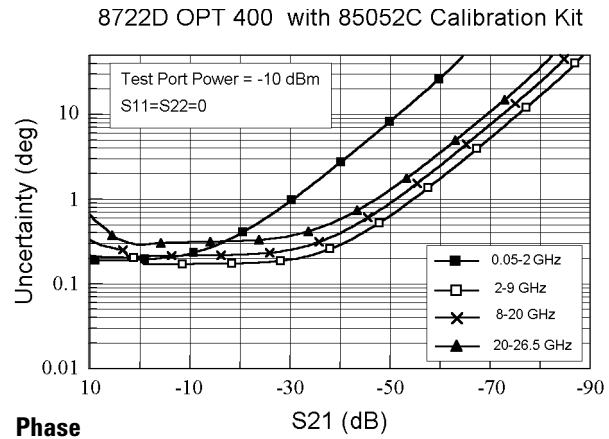

Phase

System performance (continued)

Agilent 8719D, 8720D, 8722D Option 007

Agilent 8719D, 8720D, 8722D Option 085

Includes instruments with Options 012 and/or 089

Option 007 replaces the standard solid-state transfer switch with a mechanical switch to provide higher output power.

Option 085 adds internally controlled 0 to 55 dB step attenuators (5 dB steps) in the receiver path of both ports, an RF loop that allows the addition of an amplifier before the transfer switch, and RF loops after the switch that allow insertion of isolators, required for measurements above 1 watt. An internal reference channel switch is added and internal bias tees are deleted. This system is capable of full two-port calibrated measurements to 20 watts. Measurements up to 100 watts may be possible using specific configurations. Option 085 is not compatible with Option 400.

System dynamic range

Frequency Range	Option 007		Option 085	
	8719D/20D	8722D	8719D/20D	8722D
0.05 GHz	82 dB	72 dB	77 dB	67 dB
0.05 to 2 GHz ¹	105 dB	98 dB	100 dB	93 dB
2 to 8 GHz	105 dB	98 dB	100 dB	93 dB
8 to 20 GHz	105 dB	96 dB	100 dB	91 dB
20 to 40 GHz	—	85 dB	—	77 dB

1. Rolls off below 840 MHz to specified value at 50 MHz

Maximum output power

	Option 007	Option 085 ²
8719D/8720D	+10 dBm	+5 dBm
8722D (0.05 to 20 GHz)	0 dBm	-5 dBm
8722D (20 to 40 GHz)	-5 dBm	-10 dBm

2. With jumper cable installed between RF out and RF in ports, i.e. no external amplification.

Supplemental characteristics (Option 085)

Maximum R-channel input level: 0 dBm

Minimum R-channel input level: -34 dBm

Maximum RF port input: +43 dBm

Attenuators: 55 dB maximum, 5 dB steps

Maximum test port power (no isolators): +30 dBm

Maximum test port power (with high power isolators): +43 dBm

Option 085 block diagram and example high power measurement setup

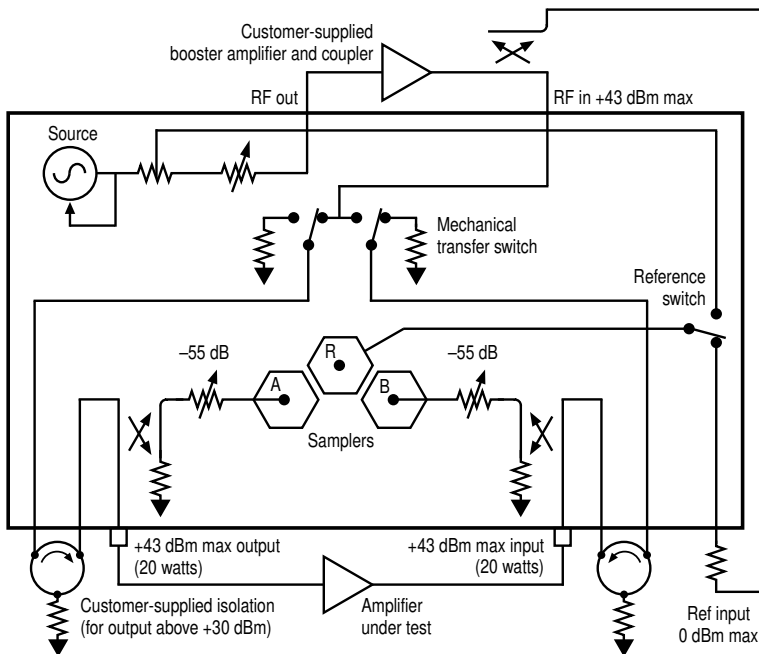

Agilent 8719D or 8720D with Option 007 or 085

Calibration kit: Agilent 85052B 3.5 mm with sliding loads

Cables: Agilent 85131F 3.5 mm flexible cable set

IF bandwidth: 10 Hz

Averaging: None (8 during isolation calibration)

Corrected measurement port characteristics

	Frequency Range (GHz)			
	0.05 to 0.5	0.5 to 2	2 to 8	8 to 20
Directivity	48 dB	48 dB	44 dB	44 dB
Source Match	40 dB	39 dB	32 dB	30 dB
Load Match	48 dB	45 dB	38 dB	37 dB
Reflection Tracking	±0.006 dB	±0.010 dB	±0.030 dB	±0.031 dB
Transmission Tracking	±0.011 dB	±0.016 dB	±0.070 dB	±0.122 dB

Measurement uncertainty

Reflection measurements

8720D OPT 007/085 with 85052B Calibration Kit

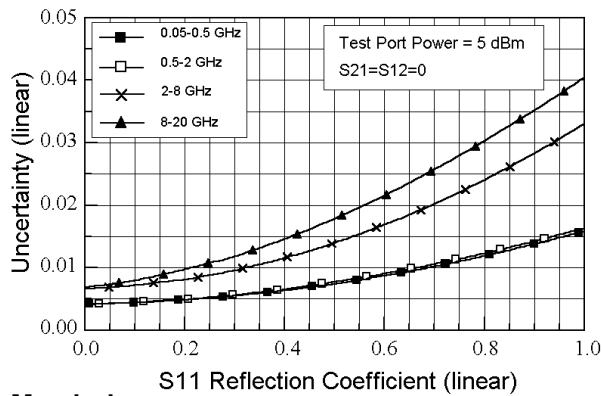

Magnitude

8720D OPT 007/085 with 85052B Calibration Kit

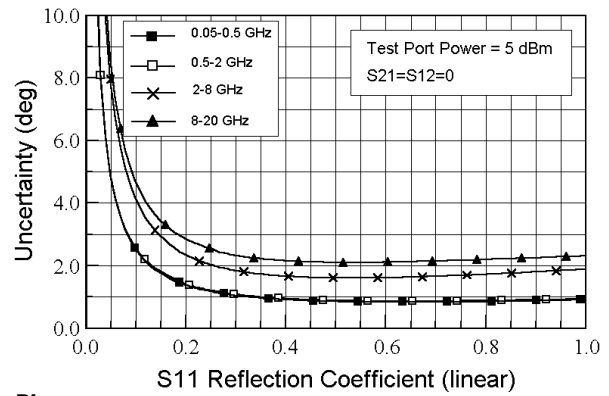

Phase

Transmission measurements

8720D OPT 007/085 with 85052B Calibration Kit

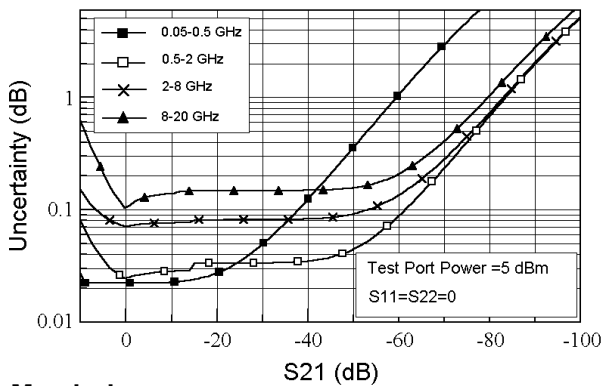

Magnitude

8720D OPT 007/085 with 85052B Calibration Kit

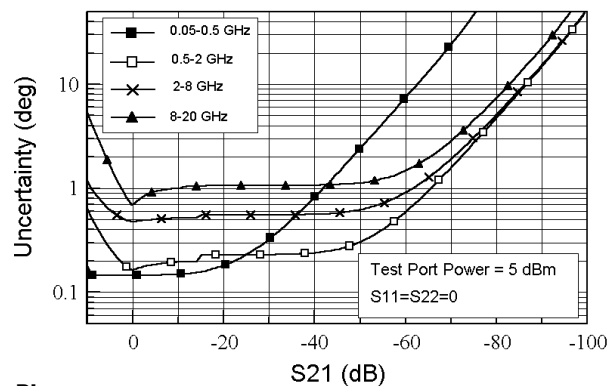

Phase

System performance (continued)

Agilent 8722D with Option 007 or 085

Calibration kit: Agilent 85052A 2.4 mm with sliding loads

Cables: Agilent 85131F 2.4 mm flexible cable set

IF bandwidth: 10 Hz

Averaging: None (8 during isolation calibration)

Corrected measurement port characteristics

	Frequency Range (GHz)			
	0.05 to 2	2 to 8	8 to 20	20 to 40
Directivity	42 dB	42 dB	42 dB	38 dB
Source Match	40 dB	35 dB	34 dB	31 dB
Load Match	41 dB	48 dB	37 dB	35 dB
Reflection Tracking	±0.011 dB	±0.037 dB	±0.039 dB	±0.047 dB
Transmission Tracking	±0.019 dB	±0.054 dB	±0.082 dB	±0.145 dB

Measurement uncertainty

Reflection measurements

8722D OPT 007/085 with 85056A Calibration Kit

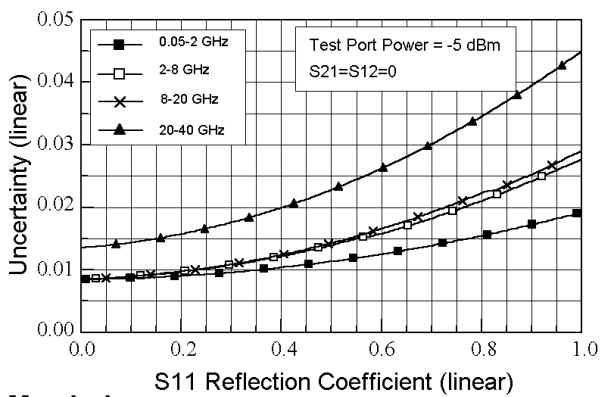

8722D OPT 007/085 with 85056A Calibration Kit

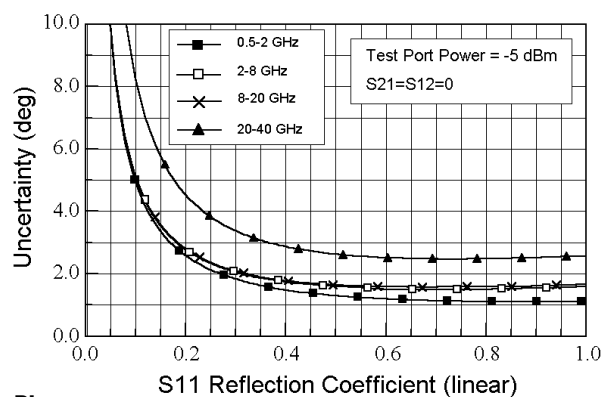

Transmission measurements

8722D OPT 007/085 with 85056A Calibration Kit

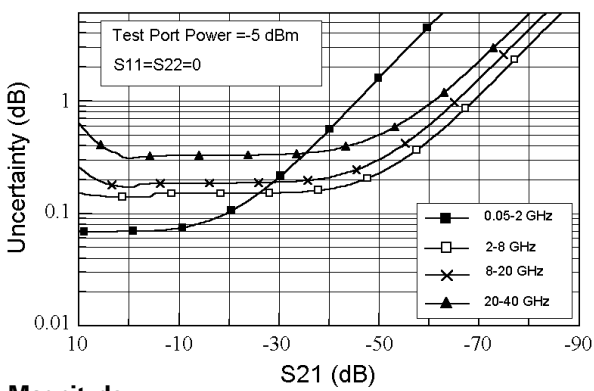

8722D OPT 007/085 with 85056A Calibration Kit

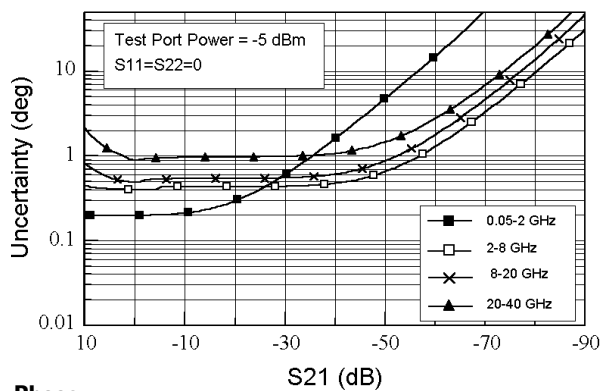

Option 012

Option 012 adds RF loops that provide direct access to the A and B samplers in the port 1 and port 2 receivers. This allows transmission measurements that bypass the receiver coupler for improved signal-to-noise and sensitivity. The system is capable of antenna measurements to -110 dBm at 40 GHz, and filter rejection measurements to 120 dB. Use of multiple antennae provides improved signal-to-noise for free space transmission and reflection measurements. The RF loops can also be used to integrate components into the test set. Adding a 20 dB attenuator increases the test port 0.1 dB compression level to +30 dBm. With front panel jumpers installed, the system operates as a standard system and meets standard instrument specifications.

Option 012 test set block diagram

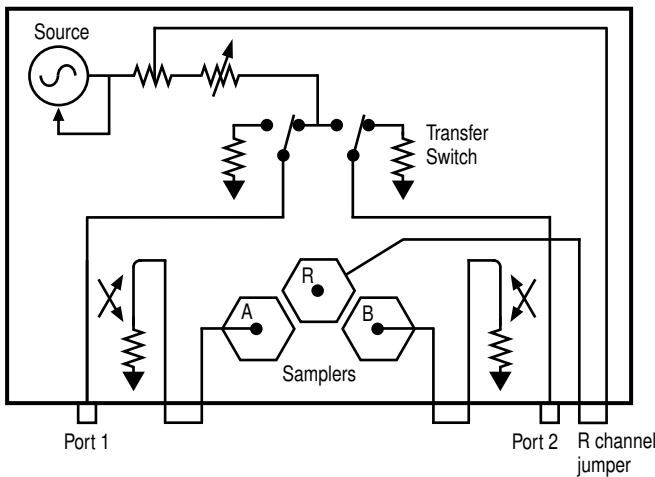

Option 400 and 012 test set block diagram

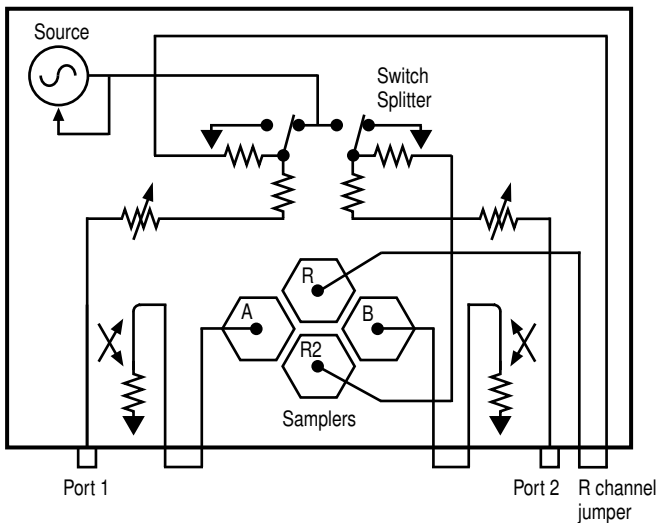

Supplemental characteristics (Option 012)

	Frequency Range (GHz)				
	0.05 to 0.5	0.5 to 2	2 to 8	8 to 20	20 to 40
Compression ¹					
Test Port ^{1,2}	20 dB	16 dB	15 dB	8 dB	3 dB
Compression ¹					
Direct					
Sampler Input	2 dBm	1 dBm	0 dBm	-7 dBm	-12 dBm
Average					
Noise Floor ²	-125 dBm	-125 dBm	-125 dBm	-123 dBm	-120 dBm
Receiver					
Dynamic Range	127 dB	126 dB	125 dB	116 dB	108 dB

1. Input power level that causes 0.1 dB compression in the receiver

2. 10 Hz IF BW

Measure filter rejection to -120 dB

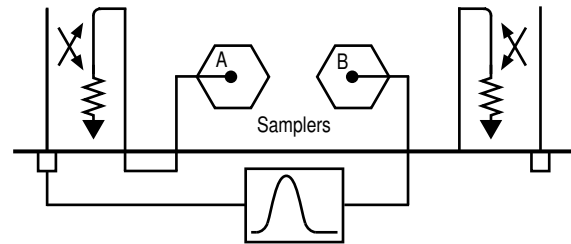

Measure amplifier output to +43 dBm

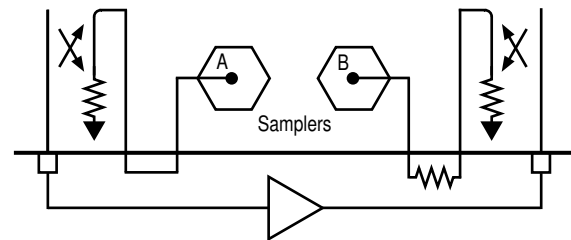

16 dB more sensitivity for antenna test. Improved signal to noise for free space materials test.

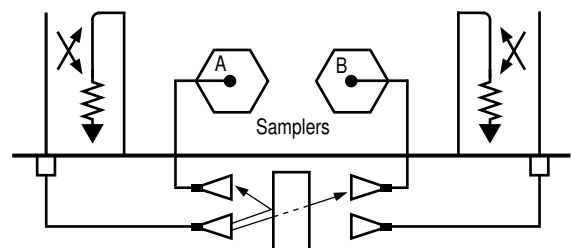

System performance (continued)

Option 089

Option 089 adds frequency offset mode, allowing the receiver to be offset from the source frequency. This allows direct conversion loss measurement of mixers without need for a reference mixer. RF and IF frequencies must be within the specified operating range of the instrument. This test set modification adds an internal reference channel switch and deletes the reference channel output. Firmware guides the user through test setup. When not in frequency offset mode, the system operates as a standard system and meets standard instrument specifications.

Supplemental characteristics (Option 089)

	8719D/8720D	8722D
Reference (R) Input Level		
Minimum	-34 dBm	-34 dBm
Maximum (for 0.1 dB compression)	-7 dBm	-12 dBm
Maximum (damage level)	0 dBm	0 dBm

Note: To utilize full instrument receiver dynamic range, measure test signal at port 2. This configuration requires a power splitter and reference mixer to provide a phase lock signal to the R channel input.

Analyzer's guided test setup display

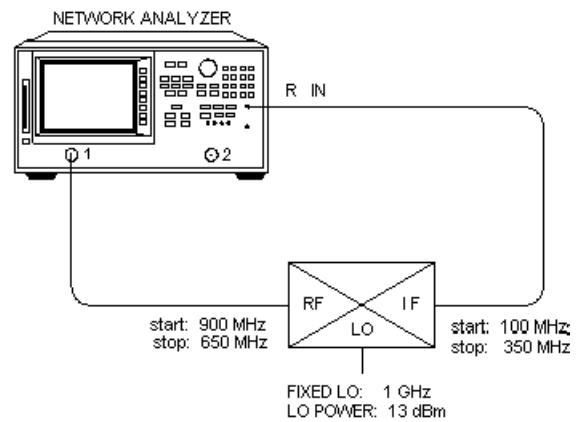

Option 089 test set block diagram

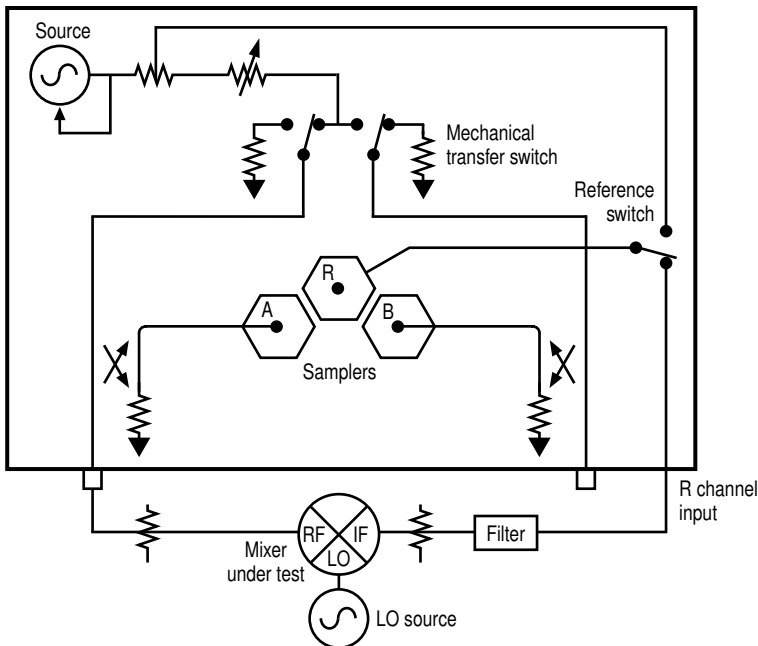

Specifications and characteristics

Description	Specification	Code	Description	Specification	Code
Frequency Characteristics			Power Characteristics		
Range			Power Range		
8719D	0.05 to 13.51 GHz	S-1	8719D/8720D	75 dB	C
8720D	0.05 to 20.05 GHz	S-1	8722D		
8722D	0.05 to 40 GHz	S-1	0.05 to 20 GHz	70 dB	C
Accuracy (at 23 °C ± 3 °C)	±10 ppm	S-1	20 to 40 GHz	65 dB	C
Stability			Maximum Output Power		
0 °C to 55 °C	±7.5 ppm	C	8719D/8720D (Standard, Options. 085, 400)	+5 dBm	C
Option 1D5	±0.05 ppm	C	8719D/8720D (Option 007)	+10 dBm	C
Per year (aging)	±3 ppm	C	8722D (Standard, Options 085, 400)		
Option 1D5	±0.5 ppm	C	0.05 to 20 GHz	-5 dBm	C
Resolution	1 Hz	S-3	20 to 40 GHz	-10 dBm	C
System Characteristics			8722D (Option 007)		
Maximum Input Level			0.05 to 20 GHz	0 dBm	C
Damage Level (test port)	30 dBm	C	20 to 40 GHz	-5 dBm	C
Reference (F) Input Level (Option 089)			Resolution	0.01 dB	S-3
Maximum			Flatness (at 5 dB below maximum output power)		
8719D/8720D	-7 dBm	C	8719D/8720D	±2 dB	S-1
8722D	-12 dBm	C	8722D	±3 dB	S-1
Minimum			Power Sweep Range		
8719D/8720D/8722D	-34 dBm	C	8719D	20 dB	S-3
High Level Trace Noise ²			8720D	20 dB	S-3
Magnitude (zero-peak)			8722D	15 dB	S-3
0.05 to 13.5 GHz	0.03 dB	C	Power Linearity		
13.5 to 20 GHz	0.04 dB	C	±5 dB from reference	±0.35 dB	S-1
20 to 40 GHz	0.15 dB	C	-10 dB from reference	±0.6 dB	S-1
Phase (zero-peak)			+10 dB ³ from reference	±1 dB	S-1
0.05 to 13.5 GHz	0.3°	C	Test Reference Power		
13.5 to 20 GHz	0.4°	C	8719D/8720D (Standard, Options 085, 400)	-5 dBm	S-3
20 to 40 GHz	1.5°	C	8719D/8720D (Option 007)	0 dBm	S-3
Spectral Purity Characteristics			8722D (Standard, Options 085, 400)	-10 dBm	S-3
Harmonics at maximum output level	<-15 dBc	C	8722D (Option 007)		
Phase Noise			<hr/>		
to 60 kHz from carrier at 2 GHz	<-55 dBc	C			
to 60 kHz from carrier at 20 GHz	<-35 dBc	C			
Nonharmonic Spurious Signals					
at 100 kHz offset	<-40 dBc	C			
at 200 kHz offset	<-45 dBc	C			
at >200 kHz offset	<-65 dBc	C			

Description	Frequency Range (GHz)					Code
	0.05 ⁵	0.05 to 2 ⁵	2 to 8	8 to 20	20 to 40	
System Characteristics						
Dynamic Range ³						
8719D/8720D						
(Standard, Options 085, 400)	77 dB	100 dB	100 dB	100 dB		S-1
8719D/8720D (Option 007)	82 dB	105 dB	105 dB	105 dB		S-1
8722D (Standard ⁴ , Options 085, 400)	67 dB	93 dB	93 dB	91 dB	80 dB ⁶	S-1
8722D (Option 007)	72 dB	98 dB	98 dB	96 dB	85 dB	S-1
Receiver 0.1 dB Compression Input Level ⁷	20 dBm	16 dBm	15 dBm	8 dBm	3 dBm	C

- Does not apply to 8722D.
- Trace noise is defined as variation of a high signal level trace due to noise. The value given represents a noise variation that is three standard deviations away from the trace's mean value as measured in a 3 kHz IF bandwidth in the fast sweep mode (STEP SWP OFF).
- The dynamic range specifications apply to transmission measurements using 10 Hz IF BW and response and isolation correction or full two-port correction. Dynamic range is limited by the maximum test port power and the receiver's noise floor.
- With 85133E flexible cable on test port.
- Rolls off below 840 MHz to specified value at 50 MHz.
- 77 dB for Option 085.
- For Option 012 direct sampler input compression levels, refer to page 9.

- S-1: This performance parameter is verifiable using performance tests documented in the service manual.
- S-2: Due to limitations on available industry standards, the guaranteed performance of the instrument cannot be verified outside the factory. Field procedures can verify performance with a confidence prescribed by available standards.
- S-3: These specifications are generally digital functions or are mathematically derived from tested specifications, and can therefore be verified by functional pass/fail testing.
- C: Non-warranted performance characteristics are intended to provide information useful in applying the instrument. Performance characteristics are representative of most instruments, though not necessarily tested in each unit. Not field tested.

Measurement throughput summary

Full frequency band sweep time (ms)¹

Measurement	Number of Points			
	51	201	401	1601
(Stepped mode/Swept mode)				
Single Band Sweep (10 to 12 GHz)				
Uncorrected	170/56	523/93	999/143	3866/443
One-port calibration ²	170/56	523/93	999/143	3866/443
Two-port calibration ³	331/100	1053/173	2024/272	7880/872
Agilent 8719D Full Sweep (0.05 to 13.5 GHz)				
Uncorrected	612/496	1055/589	1539/651	4371/951
One-port calibration ²	612/496	1055/589	1539/651	4371/951
Two-port calibration ³	1217/977	2118/1166	3100/1287	8911/1892
Agilent 8720D Full Sweep (0.05 to 20 GHz)				
Uncorrected	585/447	1068/580	1548/637	4386/939
One-port calibration ²	585/447	1068/580	1548/637	4386/939
Two-port calibration ³	1162/880	2144/1147	3123/1263	8942/1865
Agilent 8722D Full Sweep (0.05 to 40 GHz)				
Uncorrected	760/581	1281/696	1733/713	4649/995
One-port calibration ²	760/581	1281/696	1733/713	4649/995
Two-port calibration ³	1510/1144	2572/1376	3497/1414	9478/1976
Time Domain Conversion⁴		44	90	387
 GPIB Data Transfer⁵	13	18	25	61
Binary (Internal)				
IEEE754 floating point format				
32 bit	14	21	31	89
64 bit	16	30	48	153
ASCII	52	181	355	1391

1. All values are typical.
2. S11 one-port calibration, with a 6 kHz IF bandwidth. Includes system retrace time. Time domain gating is assumed off.
3. S21 measurement with full two-port calibration, using a 6 kHz IF bandwidth. Includes system retrace time and RF switching time. Time domain gating is assumed off.
4. Option 010 only, gating and error-correction are off. Does not include sweep time.
5. Measured with an HP Omnibook 5500 133 Pentium computer.

Analyzer options

Option 010 time domain

With the time domain option, data from transmission or reflection measurements in the frequency domain are converted to the time domain using a Fourier transformation technique (chirp Z) and presented on the display. The time domain response shows the measured parameter value versus time. Markers may also be displayed in electrical length (or physical length if the relative propagation velocity is entered).

Time stimulus modes

Standard stimulus

Two types of time excitation stimulus waveforms can be simulated during the transformations, a step and an impulse.

External stimulus

Other time excitation stimulus waveforms can be accomplished using an external controller.

Low pass step

This stimulus, similar to a traditional time domain reflectometer (TDR) stimulus waveform, is used to measure low pass devices. The frequency domain data should extend from DC (extrapolated value) to a higher value, the upper limit being defined by the test configuration used. The time domain response shows the parameter value versus time (multiply by the speed of light, c , to obtain electrical length or by c and V_{rel} to obtain physical length). The step response is typically used for reflection measurements only.

Low pass impulse

This stimulus is also used to measure low pass devices. The frequency domain data should extend from DC (extrapolated value) to a higher value, the maximum frequency determined by the test configuration. The time domain response shows changes in the parameter value versus time. The impulse response can be used for reflection or transmission measurements.

Bandpass impulse

The bandpass impulse simulates a pulsed RF signal (with an impulse envelope) and is used to measure the time domain response of band-limited devices. The start and stop frequencies are selectable by the user to any values within the limits of the test set used. The bandpass time domain response also

shows changes in the parameter values versus time. Bandpass time domain responses are useful for both reflection and transmission measurements.

Time domain range

The “alias-free” range over which the display is free of response repetition, depends on the frequency span and the number of points. Range, in nanoseconds, is determined by:

$$\text{Range} = 1/\Delta F = (\text{Number of points in Frequency Domain} - 1) / \text{Frequency Span (GHz)}$$

Range resolution

Time resolution of a time domain response (for example, 0.3 nanoseconds versus 0.307 nanoseconds).

$$\text{Range} - \text{resolution} = \text{time span} / (\text{number of points} - 1)$$

Distance

Related to time by speed of light and relative velocity; in space, $V_{rel} = 1$; for distance to response in reflection measurement, multiply by $1/2$.

$$\text{Distance} = 3 \times 10^8 \text{ m/sec} \times V_{rel} \times \text{Time}$$

Windows

The windowing function can be used to modify (filter) the frequency domain data and thereby reduce overshoot and ringing in the time domain response. Three types of windows are available—minimum, normal, and maximum.

Gating

The gating function can be used to selectively remove reflection or transmission time domain responses. In converting back to the frequency domain the effects of the responses outside the gate are removed. The location and span of the gate can be controlled by either setting the center position and time span of the gate, or by setting the start and stop time of the gate.

Analyzer options (continued)

Option 085, high power system

This option is designed to permit the measurement of high power amplifiers at RF levels up to 20 Watts (+43 dBm), with full two-port calibration. A switch is added to the reference path so that booster amplifier response can be ratioed out. To protect the analyzer from high power levels, this option allows the addition of isolators at both test ports and includes internally controlled step attenuators between couplers and samplers. Bias tees, isolators and booster amplifiers are not included. Network analyzers with option 085 can also be configured to operate as standard instruments with degraded power accuracy or as instruments capable of making single connection multiple measurements.

Option 007, mechanical transfer switch

This option replaces the solid state transfer switch with a mechanical switch in the test set, increasing the test port power and dynamic range.

Option 089, frequency offset mode

This option adds the ability to offset the source and receiver frequencies for frequency translated measurements. This provides the instrument with mixer measurement capability. It also provides a graphical setup that allows easy configuration of your measurement.

Option 1D5, high stability frequency reference

This option provides the analyzer with ± 0.05 ppm temperature stability from 0 °C to 60 °C (referenced to 25 °C).

Option 012, direct access receiver configuration

This option provides front panel access to the A and B samplers for improved receiver sensitivity. Option 012 improves signal-to-noise in free space materials measurements with the use of multiple antennas. Direct connection of the reflection antennas to the A and B samplers eliminates internal reflections of the transmitted signal in the reflection path, improving the signal to noise ratio. Option 012 also allows you to add attenuators between the couplers and samplers, increasing the power handling capability of the instrument.

Option 400, fourth sampler and TRL calibration firmware

This option converts the built-in test set to a four-sampler configuration, allowing TRL calibration. This provides the highest accuracy for non-coaxial environments, such as on-wafer probing, in-fixture or waveguide measurements.

Capabilities

Measurement capabilities

Number of measurement channels

2; each fully independent

Parameters

S_{11} : Forward reflection (input match)

S_{21} : Forward transmission (insertion loss/gain/phase)

S_{12} : Reverse transmission (reverse isolation)

S_{22} : Reverse reflection (output match)

A , B , R : Receiver signal level

A/R , B/R , A/B : Ratioed receiver signals

Auxiliary Input: DC voltage on AUX INPUT

Parameter conversion

Z – Reflection: equivalent parallel impedance

Y – Reflection: equivalent parallel admittance

Z – Transmission: equivalent series impedance

Y – Transmission: equivalent series admittance

1/S: complex inverse of S-parameters

Display formats

Cartesian

Log/linear magnitude, phase, group delay, SWR, real and imaginary

Smith chart

Log/linear magnitude and phase, R+jX, G+jB, or real/imaginary markers

Polar

Linear/log magnitude, phase, or real and imaginary markers

Markers

Number of markers

5 per channel; 1 “active” per channel; can be coupled (same stimulus in both channels) or uncoupled (independent stimulus in each channel).

Displayed marker values

All activated markers with both stimulus and response values are displayed; with dual-channel uncoupled, can display up to 10 markers; all but active marker replaced by bandwidths or statistics, when enabled.

Stimulus resolution

Discrete (actual measurement points) or continuous (linearly interpolated between points, with 1 Hz resolution).

Delta markers

Displays difference in both stimulus (e.g. frequency) and response (e.g. dB) between active marker and reference marker; reference marker may be any of five markers, or a sixth fixed marker given any arbitrary position on display.

Polar format markers

Linear magnitude and phase; log magnitude (dB) and phase; real and imaginary.

Smith chart format markers

Linear magnitude and phase; log magnitude (dB) and phase; real and imaginary (R+jI); complex impedance (R+jX); complex admittance (G+jB).

Search

Finds maximum, minimum, or target value.

Bandwidth

Finds and displays center frequency, bandwidth at a user-defined level (for example, -3 dB), Q factor, and shape factor (ratio of 60 dB and 6 dB bandwidths); updates while tuning with tracking enabled; valid for band-pass or band-reject (notch) filters.

Statistics

Calculates and displays mean, standard deviation, and peak-to-peak deviation of trace; active between two markers or over entire trace.

Tracking

Performs new search (min/max/target) at end of each sweep; if disabled, occurs once on demand.

Marker-to functions

Set start, stop or center to active marker stimulus values; set span to active and delta marker stimulus values; set reference to active marker response value; set electrical delay to active marker phase response value.

Group delay characteristics

Group delay is computed by measuring the phase change within a specified frequency step (determined by the frequency span, and the number of points per sweep).

Aperture

Selectable. Maximum aperture: 20% of frequency span. Minimum aperture: (frequency span)/(number of points-1).

Range

The maximum delay is limited to measuring no more than 180° of phase change within the minimum aperture. Range= 1/(2 x minimum aperture).

Accuracy

In general, the following formula can be used to determine the accuracy, in seconds, of a specific group delay measurement:
 $\pm(0.003 \times \text{Phase accuracy(deg)})/\text{Aperture(Hz)}$.

Capabilities (continued)

Source control

Sweep limits

Set start/stop or center/span of the stimulus parameter (frequency, power, time) directly through the source control keys and the control knob, the step keys, or the data entry keyboard.

Sweep type

Set a linear or logarithmic sweep, an arbitrarily defined frequency list, a power sweep, or a CW (single frequency) type of sweep.

Fast swept list

Define up to 30 different subsweep frequency ranges in any combination of CW, CW-delta F, or start-stop sweep modes. Set test-port power levels and IF bandwidth independently for each segment.

Measured number of points per sweep

Linear frequency: choose 3, 11, 21, 51, 101, 201, 401, 801, 1601 points.

Source coupling

Set a coupled channel sweep (same stimulus conditions on both channels) or an uncoupled channel sweep (independent stimulus conditions).

Chop/alternate sweeps

Select whether to alternately or simultaneously (chop) measure channels when measuring with two-port calibration. Chop mode is faster, while alternate mode optimizes dynamic range. The default is chop mode.

Sweep time

Set sweep time in seconds, minutes, or hours. Minimum sweep time is dependent on number of data points per sweep and selected IF bandwidth.

Auto sweep time

Select auto sweep time by entering zero seconds sweep time. The analyzer will sweep at the minimum sweep time for any subsequently selected stimulus conditions. Auto sweep time is the default condition.

Sweep trigger

Set to either continuous, hold, single, group sweep, or external trigger. Set external trigger to take a complete sweep or to measure individual points in a frequency, power, or list sweep.

Power

Control the test port signal by setting the internal attenuator over a 70 dB range. Power trip automatically reduces source power to its minimum value when excessive signal levels are incident on the

receiver test port. A caution message is also displayed. Source power range differs depending on the selected options. Power slope can be set in dBm/GHz.

Continuous switching

Continuously switches the RF output between port 1 and port 2; enables simultaneous active display of forward and reverse parameters.

Power meter calibration

Description

Use a power meter to set leveled input or output power at the device under test at a single point or an entire sweep. With an Agilent 436A, 437B, or 438A power meter connected, the calibration sweep measures the actual test port power. After the calibration is enabled, the internal RF source power is adjusted (within the range of -85 to +10 dBm) to achieve the selected power at the input of the device under test rather than at the test port output. GPIB control of the power meter for normalization or leveling is built-in. Logarithmic, linear, CW, and list sweeps can be calibrated.

Update Calibration

Select continuous leveling (requires a power splitter) by measuring and updating source power on each sweep or use a correction table (to modify source power) which is created with an initial single sweep.

Number of readings

Make single or multiple power meter readings at each frequency.

Data accuracy enhancement

Description

Measurement calibration is the process that significantly reduces measurement uncertainty due to system directivity, source and load match, tracking and crosstalk. A wide range of calibrations are available for the Agilent 8719D/20D/22D. Full two-port calibration removes all the systematic errors, resulting in the most accurate measurements.

Frequency response

Simultaneous magnitude and phase correction of frequency response errors for either reflection or transmission measurements. Requires a short or open circuit termination (reflection), or a through connection (transmission).

Response and isolation

Compensates for frequency response and directivity (reflection) or frequency response and crosstalk errors. Requires an open, short, and load circuit termination (reflection) and a through connection and load termination (transmission).

One-port calibration

Uses test set port 1, or port 2, or both to correct for directivity, frequency response, and source match errors. Requires open, short, and load.

Two-port calibration

Compensates for directivity, source match, reflection frequency response, load match, transmission frequency response, and crosstalk. Crosstalk calibration can be eliminated. Requires open, short, and load terminations for both ports plus a through connection.

TRL*/LRM* calibration

Compensates for directivity, reflection and transmission frequency response, and crosstalk in both the forward and reverse directions. Especially suitable for calibrating non-coaxial environments, such as in test fixtures. Requires through, reflect, and line or match standards. TRL*/LRM* is a special implementation of TRL/LRM calibration modified for the three-sampler receiver in the standard Agilent 8719D/20D/22D.

TRL/LRM calibration

With Option 400 (four-sampler receiver). TRL/LRM provides the highest accuracy for non-coaxial test environments such as in fixture, on-wafer or in waveguide. Compensates for directivity, reflection and transmission frequency response, and crosstalk in both forward and reverse directions.

One-path, two-port calibration

Provides a full two-port error corrected measurement when the device under test is turned around and measured in both directions.

Calibration Features

Fast two-port

Compensates for 12-terms, similar to full two-port, except that 2 of 4 raw parameters (forward or reverse) are continuously re-measured while the remaining 2 are periodically updated at a user-selectable rate. Improves update rate for tuning, and reduces unnecessary wear on transfer switch in Option 007. [Meas] key or contact closure at rear panel foot switch connector causes full two-port update.

Interpolated error correction

With any type of accuracy enhancement applied, interpolated mode recalculates the error coefficients when the test frequencies are changed. The number of points can be increased or decreased and the start/stop frequencies can be changed, but the resulting frequency range must be within the original calibration frequency range. System performance is not specified for measurements with interpolated error correction applied.

Set Z_0

Redefine the characteristic impedance of a measurement to a value other than 50 or 75 ohms.

Velocity factor

Enter the velocity factor of your propagation medium to convert equivalent electrical length to physical length.

Electrical delay

Add or subtract delay (linear phase slope), up to +10 μ s, similar to "line stretchers," both coax or wave-guide (dispersive) modes. Secondary readout in distance computed from velocity factor.

Reference plane extension

Redefine the reference plane after calibration. A new reference plane is defined in seconds of delay from the test port and ranges between ± 1 seconds. Similar to electrical delay, but applied appropriately to each of four parameters.

Select default calibration kit

Select from a list of standard calibration kits: 7 mm, 3.5 mm, Type-N 50 ohm, Type-N 75 ohm, 2.4 mm, 2.92 mm, and 3.5 mm TRL. You can also define the standards (for example, open circuit capacitance coefficients, offset short length, or fixed loads) of a user-defined kit.

Segmented calibration

Calibration remains valid for any frequency segment (in frequency list mode), after calibrating all segments with a single calibration.

Receiver power calibration

Adjusts nonratioed receiver inputs to absolute (non-ratioed) power level. Displays absolute power in dBm. Requires reference sweep of known source power.

Data averaging

IF bandwidth

The IF bandwidth is selectable from 6 kHz to 10 Hz bandwidth to reduce the effective displayed noise floor of the instrument.

Weighted sweep-to-sweep averaging

Averages vector data on each successive sweep. $A(n) = S(n)/F + (1-1/F) \times A(N-1)$ where $A(n)$ is the current average, $S(n)$ is the current input signal and F is the averaging factor. Averaging factors range from 1 to 999.

Trace smoothing

Similar to video filtering, this function computes the moving average of adjacent data points. Smoothing aperture defines the trace width (number of points) to be averaged, and ranges from 0.25% to 20% of the trace width. This function also sets the aperture for group delay measurements.

Capabilities (continued)

Display control

Display formats

Single channel dual channel overlay (both traces on one graticule), dual channel split (each trace on separate graticules).

Trace functions

Display data

Display current measurement data, memory data, or current measurement and memory data simultaneously.

Trace math

Vector division or subtraction of current linear measurement values and memory data.

Display annotations

Start/stop, center/span, CW frequency, source level, scale/div, reference level, marker data, soft-key functions, warning and caution messages, trace identification, and pass/fail indication.

Reference position

Ranges from the 0 (bottom) to 10 (top) graticule position.

Autoscale

Automatically selects scale resolution and reference value to center the trace on the display graticules for easy viewing.

Electrical delay

Offset measured phase or group delay by a defined amount of electrical delay, in seconds. Operates similarly to an electronic line stretcher. Amount of electrical delay can range between ± 1 seconds.

Frequency blanking

Blank out all frequency information on the display. Requires an instrument preset to re-enable frequency information on the display.

Title

Add custom titles (49 characters maximum) to the displayed measurement. Titles will be plotted when making hardcopies. Titles can also be used to display operator messages or prompts for a manual adjustment during a test sequence.

Adjust display

Control the intensity and background intensity values of the display. Also, customize the color, value, and brightness of the data traces, memory traces, reference lines, graticules, text, and warning messages. Default colors can be recalled along with one set of user-defined display values. Control is in % of full range.

Save/Recall storage

Instrument state

Up to 31 instrument states can be stored internally or recalled via the SAVE/RECALL menu. Instrument states include all control settings, active limit lines, active list frequency tables, memory trace data, active calibration coefficients, and custom display titles. Storage is in non-volatile memory.

Test sequences

Six measurement sequences can be stored or recalled via the sequencing menu. Sequences may also be recalled from Preset menu. Sequence register 6 is part of non-volatile storage and is not erased during a power cycle. If sequence 6 is titled AUTO, it will be executed when power is switched on.

Disk drive

Data, instrument states (including calibration data), user graphics, data plots (HP-GL commands), and test sequences can be stored on disk, using the analyzer's built-in disk drive or any external disk drive with command subset CS/80. Data files can be stored in MS-DOS format or Hewlett-Packard's standard LIF format in binary or ASCII formats (compatible with the Agilent 85150A microwave design system). A disk to be used for data storage can be initialized directly by the analyzer.

Data hardcopy

Data plotting

Hard copy plots are automatically produced with HP-GL compatible graphics printers such as the HP DeskJet or LaserJet (in single color or multi-color format). The analyzer provides Centronics, RS-232C, and GPIB interfaces.

Configure plots

Configure plots completely from the network analyzer by defining pen color and line type for data, text markers, graticules, and memory traces.

Functions

Plot trace(s), graticule(s), markers(s), or text including operating and system parameters.

Quadrants

Plot entire display fullpage sized or in one of four different quadrants of the plotter paper.

Data listings

Printouts of instrument data are directly produced with a printer such as the HP DeskJet 520, LaserJet, or 560C or PaintJet 3630A. Select a standard (single color) or color print. Printouts can include either the graphical display image (excluding soft-key label), or lists of numeric data; one line per stimulus point, with up to five columns defined by currently active parameters.

System Capabilities

Limit lines

Define test limit lines that appear on the display for go/no go testing. Lines may be any combination of horizontal, sloping lines, or discrete data points. Limit test TTL output available for external control or indication.

Operating parameters

Display, print or plot current instrument operating parameters.

Transform

When time domain (Option 010) is present, selects the time domain transform menu.

Instrument mode

Select external source, tuned receiver, or frequency offset mode.

External source mode

The receiver (input R) detects and phase-locks to any externally generated CW signal. Receiver inputs A and B will measure this same frequency for comparison or tracking measurements.

Auto

The input signal frequency is counted and displayed.

Manual

Measures the input signal closest to the frequency specified by the user (within -0.5 to $+5$ MHz).

Tuned receiver

Tunes the receiver for a synthesized CW input signal at a precisely specified frequency. The time bases of the external RF source or sources must be tied to the external reference input of the network analyzer (rear panel BNC). The built-in RF source is not used.

Frequency offset on/off

Sets the RF source to be swept at a frequency that is offset from the receiver as required in a swept RF/IF, fixed LO, mixer test. The maximum delay between the RF source and the R channel input is 0.3 microseconds. Frequency offset mode requires RF and IF frequencies to be in the specific range of the instrument.

Offset value

Set the offset frequency value.

Service menu

Select the desired service test, service diagnostic, service, or verification mode.

Test sequences

Description

Create, edit, save, or recall a series of front-panel keystrokes to automate a measurement. Each of the six sequence registers can hold approximately 200 instructions. Create or edit a sequence by selecting the sequence menu and then simply performing the front-panel keystrokes that would normally be used to make a manual measurement. Test sequences may contain basic stimulus and measurement functions (frequency, power, parameter, format, scale) advanced operations (time domain, limit testing, display marker values), and basic logical branching (for example, IF limit test fails DO sequence 5). Completed sequences are then saved and can be executed when you are ready to repeat the test.

Storage

Test sequences can be stored internally in RAM, to an internal or external disk drive, or loaded from a computer over the GPIB interface. Sequence 6 is saved in non-volatile storage and can be used as an autostart routine when titled AUTO.

Branching

Branch to another sequence on limit test pass/fail or the loop counter value. Subroutines are also possible via GOSUB.

Other GPIB instruments

Send simple commands to GPIB instruments via the title string.

Test sequence BNC output

Set TTL high or low on the analyzer rear panel output.

General purpose input/output

Read or write bits to the output port to control external devices such as part handlers. Eight output and five input TTL lines are available on the parallel port of the analyzer.

Other functions

Pause/continue, wait, title sequence, print sequence, duplicate sequence, pause, and select.

Capabilities (continued)

GPIB (remote) programming

Interface

GPIB interface operates to IEEE 488-1978 and IEC 625 standards and IEEE 728-1982 recommended practices.

Addressing

The GPIB address of the analyzer can be verified or set from the front panel via the local menu and can range from 0 to 30 decimal (factory set at 16).

Pass control

Allows the analyzer to request control of the GPIB (when an active controller is present) whenever it needs to output to a plotter or printer.

System controller

Allows the analyzer to become a controller on the GPIB to directly control a plotter or a printer.

Talker/listener

Allows the analyzer to become a GPIB talker/ listener when an external controller is present.

Transfer formats

Binary (internal 48-bit floating point complex format), ASCII and 32- or 64-bit IEEE 754 floating point format.

User-accessible graphics

Using a subset of HP graphics language (HP-GL), vector or text graphics may be written on the analyzer via GPIB. Up to 5 kbytes of data can be stored at one time (4 bytes per vector, 2 bytes per character).

Interface function codes

SHI, AHI, T6, L4, SRI, RLI, PPO, DC1, DT1, CI, C2, C3, CIO, E2

Upgrades

Refer to Configuration Guide.

Security

Frequency blank

Blanks all frequency information from display, including markers; requires FACTORY PRESET to re-enable.

Reset memory

Writes binary zeros to all non-volatile memory registers, erasing all instrument state and calibration data; used with PRESET.

General characteristics

Front panel connectors

Connector type

Agilent 8719D/8720D: 3.5 mm precision

Agilent 8722D: 2.4 mm precision

Impedance

50 ohms (nominal)

Rear panel connectors

External reference frequency input (EXT REF INPUT)

Frequency: 1, 2, 5, and 10 MHz (± 200 Hz at 10 MHz)

Level: -10 dBm to $+20$ dBm, characteristically

Impedance: 50 ohms

High-stability frequency reference output (Option 1D5)

Frequency: 10.0000 MHz

Frequency stability (0 °C to 55 °C): ± 0.05 ppm

Daily aging rate (after 30 days): $< 3 \times 10^{-9}$ /day

Yearly aging rate: 0.5 ppm/year

Output: 0 dBm minimum

Nominal output impedance: 50 ohms

External auxiliary input (AUX INPUT)

Input voltage limits: -10 V to $+10$ V

External AM input (EXT AM)

± 1 volt into a 5 k Ω resistor, 1 kHz maximum, resulting in approximately 8 dB/volt amplitude modulation.

External trigger (EXT TRIGGER)

Triggers on a negative TTL transition or contact closure to ground.

Test sequence output (TEST SEQ)

This connector outputs a TTL signal which can be programmed by the user in a test sequence to be high or low. By default, this output provides an end-of-sweep TTL signal. (For use with part handlers.)

Limit test output (LIMIT TEST)

This connector outputs a TTL signal of the limit test results. Pass: TTL high; Fail: TTL low.

Test port bias input (except Option 085)

Maximum voltage: $+30$ Vdc

Maximum current (no degradation in RF specifications):

± 200 mA

Maximum current: ± 1 A

External monitor: VGA video output

This connector drives external VGA monitors.

GPIB

This connector allows communication with compatible devices including external controllers, printers, plotters, disk drives, and power meters.

Parallel port

This connector is used with parallel (or Centronics interface) peripherals such as printers and plotters. It can also be used as a general purpose I/O port, with control provided by test sequencing functions.

RS-232

This connector is used with serial peripherals such as printers and plotters.

DIN keyboard

This connector is used for the optional AT compatible keyboard for titles and remote front-panel operation.

Internal memory

Typical data retention time with 3 V, 1.2 Ah battery:

At 25 °C: 11,904 days (32.6 years)

At 40 °C: 1244 days (3.4 years)

At 70 °C: 250 days (0.68 year)

Line power

48 to 66 Hz, 115 V nominal (90 V to 132 V) or 230 V nominal (198 V to 264 V), 280 VA maximum

Weight

Net: 25 kg (54 lb)

Shipping: 28 kg (61 lb)

Cabinet dimensions

222 mm (H) x 425 mm (W) x 457 mm (D) (8.75 x 16.75 x 18 in)
(These dimensions exclude front and rear panel protrusions.)

Ventilation

Allow 100 mm (4 in.) around rear and sides.

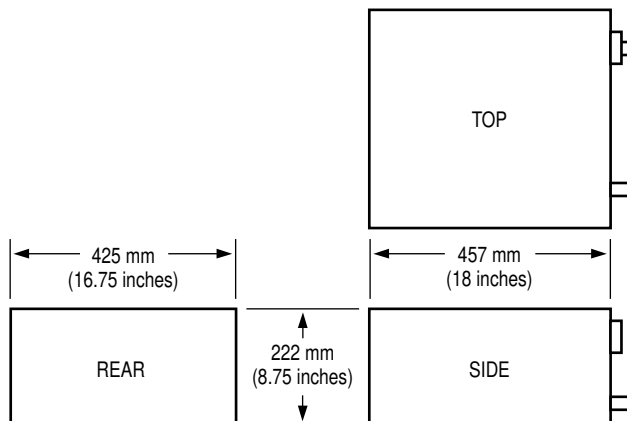

Environmental Characteristics

General Conditions

RFI and EMI susceptibility

Defined by VADE 0730, CISPR Publication 11, and FCC Class B Standards.

ESD (electrostatic discharge)

Must be eliminated by use of static-safe work procedures and an anti-static bench mat (such as Agilent 92175T).

Dust

The environment should be as dust-free as possible.

Operating conditions

Operating temperature: 0 °C to 55 °C

Error-corrected temperature Range: ±1 °C of calibration temperature

Humidity: 5% to 95% at 40 °C (noncondensing)

Altitude: 0 to 4500 meters (15,000 feet)

Non-operating storage conditions

Temperature: -40 °C to +70 °C

Humidity: 0 to 90% relative at +65 °C (noncondensing)

Altitude: 0 to 15,240 meters (50,000 feet)

Software

Agilent 85071B Materials Measurement Software Description

The 85071B software uses broadband S-parameter measurements to determine the electromagnetic properties of dielectric and magnetic materials. The software calculates both the complex permittivity ϵ_r (or dielectric constant) and permeability μ_r , including loss factors. Depending on the network analyzer and fixtures used, measurements can extend from 100 MHz to 110 GHz. The software offers the choice of four algorithms, each designed to address specific measurement needs.

Operating requirements

Standard: Requires MS-DOS on an HP Vectra (or any 100%-compatible PC-AT computer) compatible with Microsoft Windows 3.0 or higher with mouse. Requires >20 Mbyte hard disk and >640 Kbytes RAM.

Option 300: Substitutes HP BASIC Software for the standard version for operation with HP 9000 series 300 controllers. Requires BASIC 5.0 or higher and 2 Mbytes of RAM.

Performance summary

Frequency range: 100 MHz to 110 GHz (characteristically, depending on network analyzer, fixture, and material).

Format: ϵ_r' , ϵ_r'' , μ_r' , μ_r'' , $\tan \delta$, $\tan \delta_m$, or Cole-Cole plots; tabular listings of data.

Stimulus control: Frequency range, number-of-points, and linear or log sweep.

Calibration: The software can use any calibration including a calibrated response gated in the time domain.

Accuracy: 1 to 2%

Fixture: The software works with simple transmission lines: coaxial airlines, or rectangular waveguide containing a cross-sectional sample of the material-under-test.

Data display: Displays current measurement data, and can save/display 3 memory traces for comparison.

Data storage: Save/recall/export data via disk in MS-DOS® ASCII format or HP BASIC BDAT format (HP LIF binary).

Agilent 85070B Dielectric Probe Kit Description

The 85070B dielectric probe kit allows convenient non-destructive testing of materials using the open-ended coaxial probe method. The probe, together with its own dedicated software, determines the complex permittivity of a wide variety of liquids, semi-solids, and solids. Since the probe kit measures only permittivity, only non-magnetic materials should be measured. Measurements are efficient and cost-effective because the testing is non-destructive and there is no need for sample preparation or special fixtures.

Operating requirements

Standard: Requires MS-DOS on an HP Vectra (or any 100%-compatible PC-AT computer) compatible with Microsoft Windows 3.0 or higher with mouse. Requires >20 Mbyte hard disk and >640 Kbytes RAM.

Option 300: Substitutes HP BASIC Software for the standard version for operation with HP 9000 series 300 controllers. Requires BASIC 5.0 or higher and 2 Mbytes of RAM.

Performance summary

Frequency range: 200 MHz to 20 GHz (typical, depending on network analyzer, fixture, and material).

Probe Temperature

Range: -40 °C to +200 °C

Rate: <10°C per minute

Format: ϵ_r' , ϵ_r'' , $\tan \delta$, or Cole-Cole diagram in linear format.

Stimulus control: Frequency range, number-of-points, and linear or log sweep.

Calibration: Guided, using open, short (included), and deionized water. Supports user-defined standards.

Accuracy

Dielectric constant, ϵ_r' : $\pm 5\%$

Loss tangent, $\tan \delta$, ϵ_r''/ϵ_r' : ± 0.05

Data display: Displays current measurement data, and can save/display up to three memory traces for comparison.

Data storage: Save/recall/export data via disk in MS-DOS® ASCII format or HP BASIC BDAT format (HP LIF binary).

Accessories

A wide range of accessories support the Agilent 8720 family of network analyzers, including calibration kits, verification kits, cables and adapters in both 7 mm, 3.5 mm, Type-N, and 2.4 mm coax and in the standard waveguide bands. The standards used in the 3.5 mm, Type-N, and 2.4 mm calibration and verification kits use precision slotless connectors (PSC-3.5, PSC-N, and PSC-2.4).

Calibration kits

Vector accuracy enhancement procedures require that the systematic errors of the measurement system be characterized by measuring known devices (standards) on the system over the frequency range of interest. Agilent Technologies offers the following types of calibration kits:

Standard calibration kits

Contain open circuits, short circuits, and both fixed and sliding terminations in both sexes for all connector types (except 7 mm, a sexless connector). Connector gauges are included in these kits for maintaining each standard's connector interface. Standard calibration kits that include RTL adapters and devices are also available in 7 mm and 3.5 mm connectors.

Precision calibration kits

Have precision 50Ω airline(s) for performing the Thru-Reflect-Line (TRL) calibration. These kits also contain the open circuit, short circuit, and fixed terminations used for traditional open-short-load calibration techniques.

Calibration kits

Cal Kit Type and Name	Frequency Range (GHz) f_{\min} - f_{\max}	Connector Type	Return Loss, Fixed Load	Return Loss, Sliding Load	Return Loss, Airline at f_{\max}	Residual Directivity ² at f_{\max}	Residual Source Match ² at f_{\max}
Precision							
85052C	0.045 to 26.5	3.5 mm	≥46 dB, DC to 2 GHz	—	50 dB	50 dB	50 dB
Standard							
85050B	0.045 to 18	7 mm	≥52 dB, DC to 2 GHz	≥52 dB, 2 to 18 GHz	—	45 dB	30 dB
85052B	0.045 to 26.5	3.5 mm	≥44 dB, DC to 3 GHz	≥44 dB, 3 to 26.5 GHz	—	44 dB	30 dB
85054B	0.045 to 18	Type-N	≥48 dB, DC to 2 GHz	≥42 dB, 2 to 18 GHz	—	42 dB	30 dB
85056A	0.045 to 50	2.4 mm	≥42 dB, DC to 4 GHz	≥36 dB at 50 GHz	—	38 dB	31 dB
Economy							
85050D	0.045 to 18	7 mm	≥38 dB, DC to 18 GHz	—	—	36 dB	30 dB
85052D	0.045 to 26.5	3.5 mm	≥30 dB at 26.5 GHz	—	—	36 dB	29 dB
85054D	0.045 to 18	Type-N	≥34 dB at 18 GHz	—	—	34 dB	28 dB
85056D	0.045 to 50	2.4 mm	≥26 dB at 50 GHz	—	—	26 dB	23 dB
85056K	0.045 to 40	2.92 mm	≥26 dB at 40 GHz	—	—	25 dB	22 dB
Waveguide							
X11644A ¹	8.2 to 12.4	WR-90	≥42 dB, 8.2 to 12.4 GHz	50 dB	40 dB	30 dB	
P11644A ¹	12.4 to 18	WR-62	≥42 dB, 12.4 to 18 GHz		50 dB	40 dB	30 dB
K11644A ¹	18 to 26.5	WR-42	≥42 dB, 18 to 26.5 GHz		50 dB	40 dB	30 dB
R11644A	26.5 to 40	WR-28	—	46 dB	50 dB	40 dB	30 dB
Electronic							
85060A ³	1 to 18	7 mm	—	—	—	44.5 dB	39.5 dB
Option 001	0.45 to 2	7 mm	—	—	—	51 dB	44.5 dB
85062A ³	1 to 26.5	3.5 mm	—	—	—	41.5 dB	35.5 dB
Option 001	0.45 to 2	3.5 mm	—	—	—	50.5 dB	43.5 dB
85064A ³	1 to 18	Type-N	—	—	—	44.5 dB	39.5 dB
Option 001	0.45 to 2	Type-N	—	—	—	50 dB	43.5 dB

1. Airline return loss, directivity, and source match are typical values for these calibration kits.

2. Residuals based on Agilent 8720D at f_{\max} =20 GHz for 3.5 mm kits or on Agilent 8722D at f_{\max} =40 GHz for 2.4 mm kits.

3. Requires an Agilent 85060C control unit.

Economy calibration kits

Include the open circuit, short circuit, and fixed termination standards but not sliding terminations or gauges. Gauges can be ordered separately.

Waveguide calibration kits

Contain two coax-to-waveguide adapters with precision flanges, a flush short circuit, a precision waveguide line section, and either sliding or fixed terminations. They support calibration based on TRL*, offset load, or short/offset-short/load/thru methods.

Electronic calibration kits

Require an Agilent 85060C control unit for operation and Agilent 85060 series calibration modules of the appropriate connector type. The calibration modules is programmed by a control unit to present many different impedances to the test ports. A full two-port calibration can be done with a single connection. Each standard calibration kit contains the two-port calibration module and a torque wrench for proper connection. Options are available to add a lowband module to the kit, and to change the sex of the connectors of the module.

Verification kits

Measuring known devices, other than the standards used in calibration, is an easy way to verify the correct operation of an Agilent 8719D/20D/22D network analyzer system. Agilent offers the following verification kits which contain precision devices, with data traceable to NIST used to verify the analyzer's error-corrected measurement performance.

- 85051B 7 mm verification kit; 0.045 to 18 GHz
- 85055A Type-N verification kit; 0.045 to 18 GHz
- 85053B 3.5 mm verification kit; 0.045 to 26.5 GHz
- 85057B 2.4 mm verification kit; 0.045 to 50 GHz

Test port return cables

Test port cables are available in the 7 mm, 3.5 mm, Type-N, and 2.4 mm connectors types. All cables connect directly to the special ruggedized test port of the network analyzer test port (NMD connector). Agilent offers the following cable choices:

- Single cables in semi-rigid and flexible
- Cable set in semi-rigid and flexible

A single long cable with an appropriate test port adapter is best for applications where the test device requires a connection next to the test port for mechanical rigidity. A set of cables offers the flexibility required to position the test devices away from the test set.

Semi-rigid cables offer excellent performance and are suitable for applications where the connectors of the test device are “in-line” or parallel. Flexible cables are ideal for manufacturing environments since they are more rugged and have a tighter bending radius than semi-rigid cables. Semi-rigid cables are warranted for 90 days; flexible cables are warranted for 1 year.

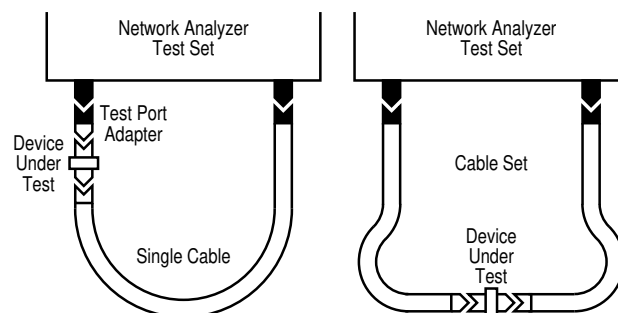

Accessories (continued)

Test port return cable specifications

	Connector Type (Test Port to Device)	Frequency (GHz)	Length ² cm (inch)	Return Loss	Insertion Loss (dB) (f in GHz)	Stability ^{1,2} ±Magnitude	±Phase (degrees)
Single cables for 8719D and 8720D (3.6 mm)							
85131C Semi-rigid Cable	3.5 mm ³ to PSC-3.5 mm (f)	DC to 26.5	81 (32)	≥17 dB	0.43 √f +0.3 (2.5 dB at f _{max})	<0.06 dB	0.16 (f) +0.5
86131E Flexible Cable	3.5 mm ³ to PSC-3.5 mm (f)	DC to 26.5	96.5 (38)	≥16 dB	0.35 √f +0.3 (2.1 dB at f _{max})	<0.22 dB	0.16 (f) +0.8
85132C Semi-rigid Cable	3.5 mm ³ to 7 mm	DC to 18	81 (32)	≥17 dB	0.35 √f +0.3 (1.8 dB at f _{max})	<0.06 dB	0.16 (f) +0.5
85132E Flexible Cable	3.5 mm ³ to 7 mm	DC to 18	97.2 (38.25)	≥17 dB	0.35 √f +0.3 (1.8 dB at f _{max})	<0.22 dB	0.16 (f) +0.8
Cable set for 8719D and 8720D (3.5 mm)							
85131D Semi-rigid Cable Set	3.5 mm ³ to PSC-3.5 mm (f) or 3.5 mm ³ (m)	DC to 26.5	53 (21)	≥16 dB	0.30 √f +0.2 (1.8 dB at f _{max})	<0.06 dB	0.16 (f) +0.5
85131F Flexible Cable Set	3.5 mm ³ to PSC-3.5 mm (f) or 3.5 mm ³ (m)	DC to 26.5	62.2 (24.5)	≥16 dB	0.25 √f +0.2 (1.5 dB at f _{max})	<0.12 dB	0.13 (f) +0.5
85132D Semi-rigid Cable Set	3.5 mm ³ to 7 mm	DC to 18	53 (21)	≥17 dB	0.25 √f +0.2 (1.3 dB at f _{max})	<0.06 dB	0.16 (f) +0.5
85132F Flexible Cable Set	3.5 mm ³ to 7 mm	DC to 18	62.9 (24.75)	≥17 dB	0.25 √f +0.2 (1.3 dB at f _{max})	<0.12 dB	0.13 (f) +0.5
Single cables for 8722D (2.4 mm)							
85133C Semi-rigid Cable	2.4 mm ³ to PSC-2.4 mm (f)	DC to 50	81 (32)	≥15 dB	0.84 √f +0.3 (5.6 dB at f _{max})	<0.06 dB	0.18 (f)
85133E Flexible Cable	2.4 mm ³ to PSC-2.4 mm (f)	DC to 50	113 (44)	≥12.5 dB	0.58 √f +0.35 (4.45 dB at f _{max})	<0.25 dB	0.8 +0.16 (f)
85134C Semi-rigid Cable	2.4 mm ³ to PSC-3.5 mm (f)	DC to 26.5	81 (32)	≥16 dB	0.46 √f +0.3 (2.7 dB at f _{max})	<0.06 dB	0.18 (f)
85134E Flexible Cable	2.4 mm ³ to PSC-3.5 mm (f)	DC to 26.5	97.2 (38.25)	≥16 dB	0.46 √f +0.3 (2.7 dB at f _{max})	<0.22 dB	0.16 (f) +0.8
85135C Semi-rigid Cable	2.4 mm ³ to 7 mm	DC to 18	81 (32)	≥17 dB	0.46 √f +0.3 (2.25 dB at f _{max})	<0.06 dB	0.18 (f)
85135E Flexible Cable	2.4 mm ³ to 7 mm	DC to 18	97.2 (38.25)	≥17 dB	0.46 √f +0.3 (2.25 dB at f _{max})	<0.22 dB	0.16 (f) +0.8
Cable set for 8722D (2.4 mm)							
85133D Semi-rigid Cable Set	2.4 mm ³ to PSC-2.4 mm (f) or 2.4 mm ³ (m)	DC to 50	53 (21)	≥15 dB	0.55 √f +0.2 (3.7 dB at f _{max})	<0.06 dB	0.16 (f)
85133F Flexible Cable Set	2.4 mm ³ to PCS-2.4 mm(f) or 2.4 mm ³ (m)	DC to 50	72 (28)	≥12.5 dB	0.48 √f +0.25 (3.64 dB at f _{max})	<0.17 dB	0.8 +0.16 (f)
85134D Semi-rigid Cable Set	2.4 mm ³ to PSC-3.5 mm (f) or 3.5 mm ³ (m)	DC to 26.5	53 (21)	≥16 dB	0.31 √f +0.2 (1.8 dB at f _{max})	<0.06 dB	0.18 (f)
85134F Flexible Cable Set	2.4 mm ³ to PSC-3.5 mm (f) or 3.5 mm ³ (m)	DC to 26.5	62.9 (24.75)	≥16 dB	0.31 √f +0.2 (1.8 dB at f _{max})	<0.12 dB	0.13 (f) +0.5
85135D Semi-rigid Cable Set	2.4 mm ³ to 7 mm	DC to 18	53 (21)	≥17 dB	0.31 √f +0.2 (1.5 dB at f _{max})	<0.06 dB	0.18 (f)
85135F Flexible Cable Set	2.4 mm ³ to 7 mm	DC to 18	62.9 (24.75)	≥17 dB	0.31 √f +0.2 (1.5 dB at f _{max})	<0.12 dB	0.13 (f) +0.5

1. Phase stability of semi-rigid/flexible cables is specified with a 90 degree bend and a 4"/3" radius.

2. Cable length and stability are supplemental characteristics.

3. Special rugged female connector specifically for connecting to the network analyzer test port, but does not mate with a standard male connector.

Test port adapter sets

The Agilent 85130 series test port adapter sets protect the test set port when connecting devices to the test port. These adapters, listed below with the single cables, convert the ruggedized test set port to a connection mateable with the device under test. Each set contains a male and a female adapter.

Adapter sets

Adapter Set	Connector Type (Test Port to Device)	Frequency (DC– f_{\max})	Return Loss at f_{\max}
85130C	3.5 mm ¹ to Type-N	DC to 18 GHz	≥28 dB
85130D	3.5 mm ¹ to PSC-3.5 mm (f) or 3.5 mm ¹ (m)	DC to 26.5 GHz	≥28 dB
85130E	2.4 mm ¹ to 7 mm	DC to 18 GHz	≥26 dB
85130F	2.4 mm ¹ to PSC-3.5 mm (f) or 3.5 mm ¹ (m)	DC to 26.5 GHz	≥26 dB
85130G	2.4 mm ¹ to PSC-2.4 mm (f) or 2.4 mm ¹ (m)	DC to 50 GHz	≥23 dB

1. Special rugged female connector specifically for connecting to the network analyzer test port, but does not mate with a standard male connector.

Equipment rack systems

Agilent 85043D Racked System Kit

The 85043D racked system kit is a rack standing 128 cm (50.5 in) high, with a width of 60 cm (24 in) and a depth of 80 cm (32 in). Complete with support rails and AC power distribution (suitable for 50 to 60 Hz, 100 to 240 VAC), the kit includes rack mounting hardware for all instruments. Thermal design is such that no rack fan is needed.

Agilent 1181A System Testmobile

The 1181A system testmobile is a unit that provides mobility for instruments, test systems, and workstations. It holds units up to 610 mm (24 in) deep. The load capacity is up to 90 kg (200 lbs) on the tilt tray and 227 kg (500 lb) total. The following accessories are available for the test mobile:

- 35181A top mounted printer/plotter stand
- 35181B keyboard holder
- 35181C 3.5 inch high storage drawer
- 35181D work surface
- 35181E anti-static work mat
- 35181G 5.25 inch high storage drawer
- 92199B power strip for US and Canada
- 92199E international power strip (IEC-320)

Agilent Technologies' Test and Measurement Support, Services, and Assistance

Agilent Technologies aims to maximize the value you receive, while minimizing your risk and problems. We strive to ensure that you get the test and measurement capabilities you paid for and obtain the support you need. Our extensive support resources and services can help you choose the right Agilent products for your applications and apply them successfully. Every instrument and system we sell has a global warranty. Support is available for at least five years beyond the production life of the product. Two concepts underlie Agilent's overall support policy: "Our Promise" and "Your Advantage."

Our Promise

"Our Promise" means your Agilent test and measurement equipment will meet its advertised performance and functionality. When you are choosing new equipment, we will help you with product information, including realistic performance specifications and practical recommendations from experienced test engineers. When you use Agilent equipment, we can verify that it works properly, help with product operation, and provide basic measurement assistance for the use of specified capabilities, at no extra cost upon request. Many self-help tools are available.

Your Advantage

"Your Advantage" means that Agilent offers a wide range of additional expert test and measurement services, which you can purchase according to your unique technical and business needs. Solve problems efficiently and gain a competitive edge by contracting with us for calibration, extra-cost upgrades, out-of-warranty repairs, and on-site education and training, as well as design, system integration, project management, and other professional services. Experienced Agilent engineers and technicians worldwide can help you maximize your productivity, optimize the return on investment of your Agilent instruments and systems, and obtain dependable measurement accuracy for the life of those products.

Get assistance with all your test and measurement needs at:
www.agilent.com/find/assist

Product specifications and descriptions in this document subject to change without notice.

Copyright © 1998, 2000 Agilent Technologies
Printed in U.S.A. 5/00
5964-9133E



Agilent Technologies

Innovating the HP Way